

SMART OFFICE

Smart Office is a multi-height locker option which means the smaller units can sit underneath furniture or be used as a standalone room divider. Options to design a bespoke flow of lockers by picking different heights in a single run, or include the planters for those decorative touches. Using artificial foliage gives a sense of bringing the outdoors in without the maintenance and mess of real plants.

Each cubical measures between 370mm and 380mm high, either 364mm or 464mm wide and 464mm deep internally. Door configurations are available from two doors up to five door units.

The doors and the carcass used for Smart Lockers are made from 18mm thick MFC, and the top and base panel is made from 25mm thick MFC. Both finished with 2mm impact resistant edges.

Each door is supplied with 90 degree concealed hinges with soft-close fitting.

Key lock is used as standard however a wide range of other locks are available for a variety of different needs.

Adhesive number 45mm squares for locker identification is also available upon request.



DIMENSIONS

SMART OFFICE
400 & 500MM WIDE
ALL 500MM DEEP

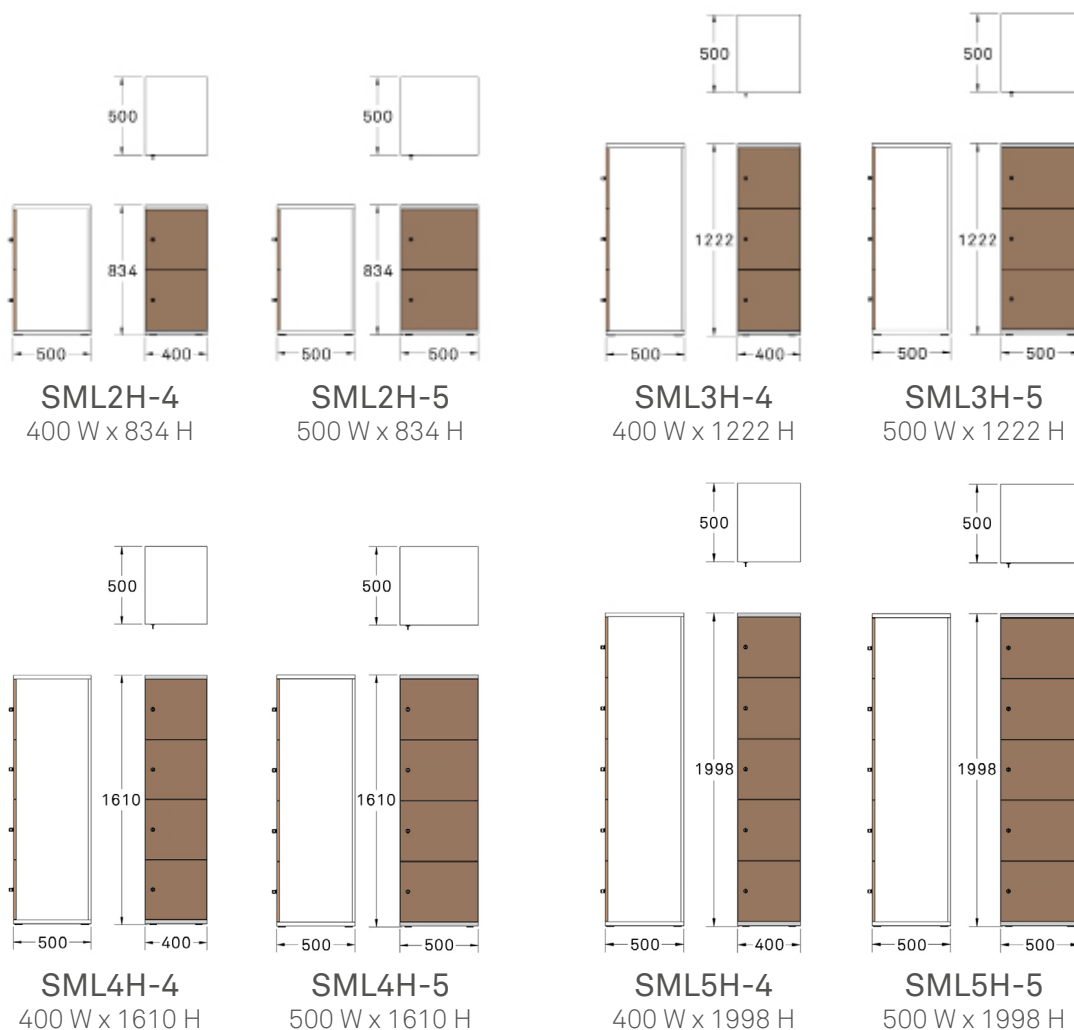

INTERNAL DIMENSIONS

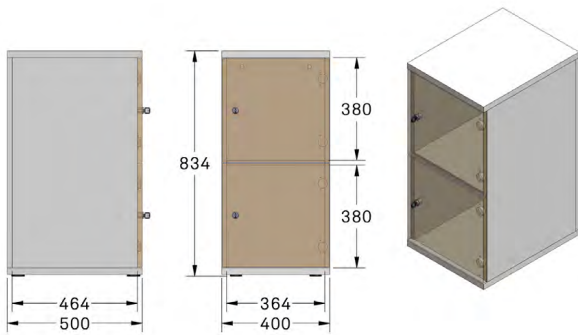

SML2H-4
COMPARTMENT INTERNAL SIZES
364 W x 380 H x 464 D

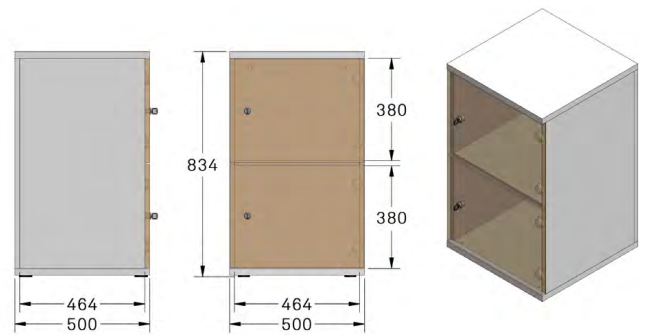

SML2H-5
COMPARTMENT INTERNAL SIZES
464 W x 380 H x 464 D

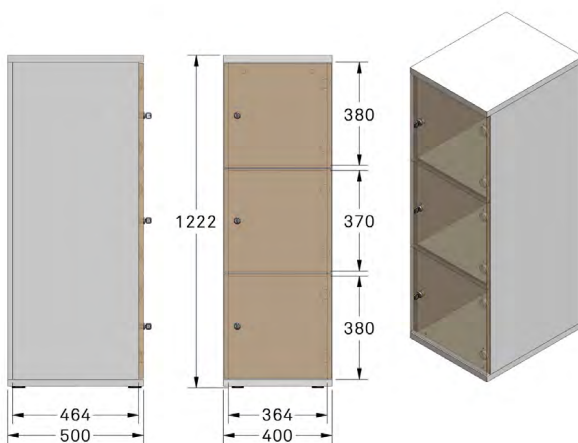

SML3H-4
COMPARTMENT INTERNAL SIZES
364 W x 370/380 H x 464 D

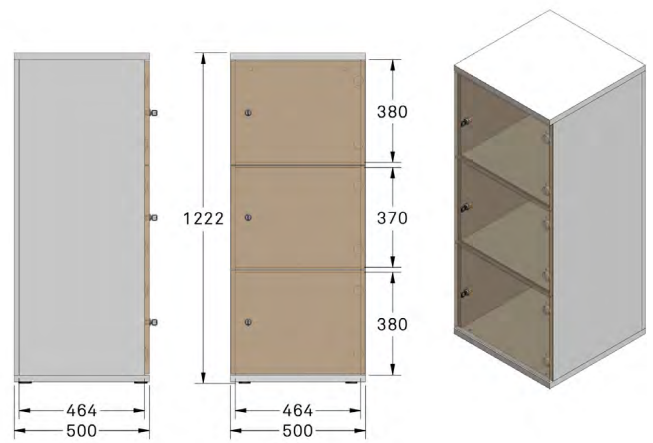

SML3H-5
COMPARTMENT INTERNAL SIZES
464 W x 370/380 H x 464 D

INTERNAL DIMENSIONS

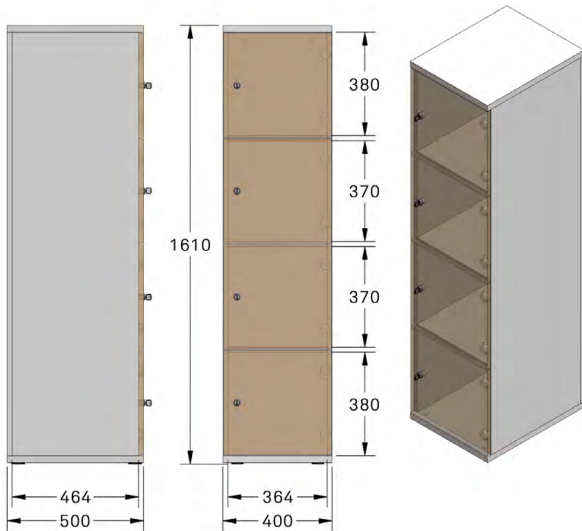

SML4H-4
COMPARTMENT INTERNAL SIZES
364 W x 370/380 H x 464 D

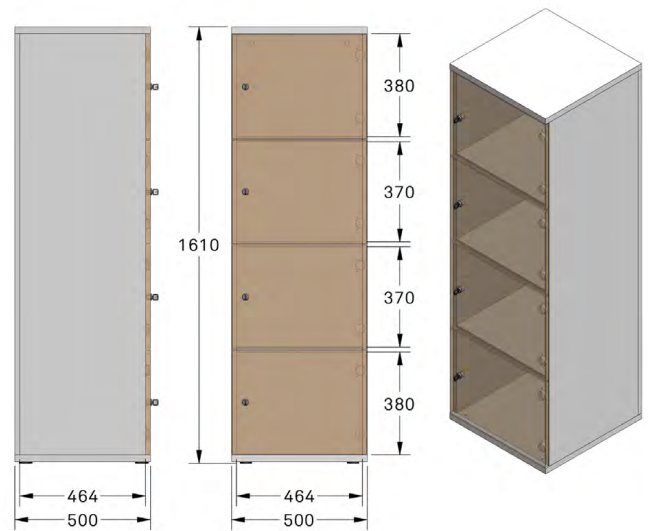

SML4H-5
COMPARTMENT INTERNAL SIZES
464 W x 370/380 H x 464 D

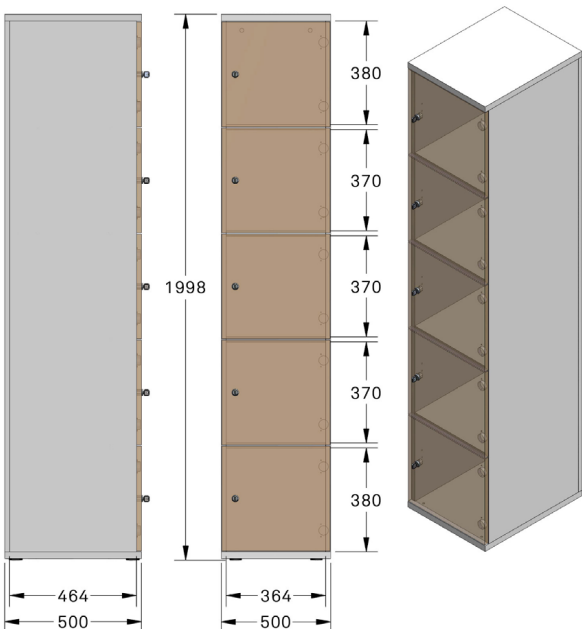

SML5H-4
COMPARTMENT INTERNAL SIZES
364 W x 370/380 H x 464 D

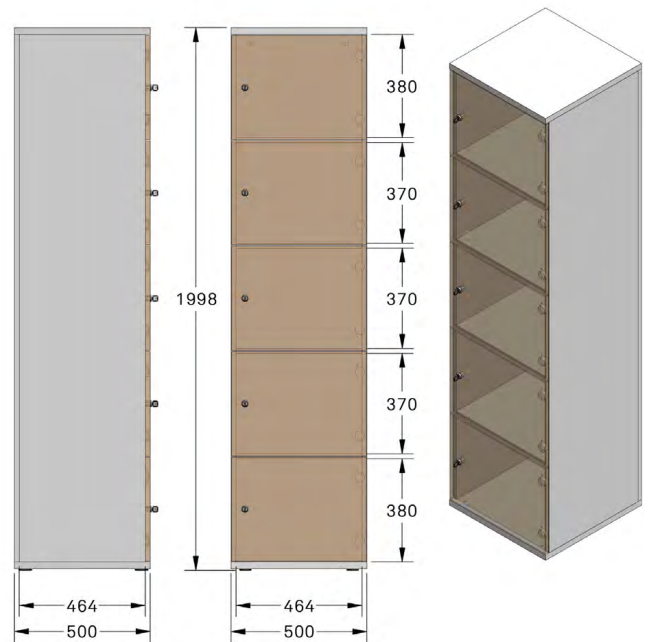

SML5H-5
COMPARTMENT INTERNAL SIZES
464 W x 370/380 H x 464 D

DIMENSIONS

SMART PLANTERS

ALL 200MM HIGH
ALL 500MM DEEP

SMP-8
800 W

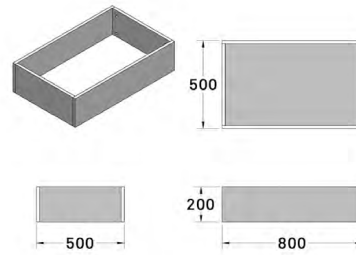

SMP-10
1000 W

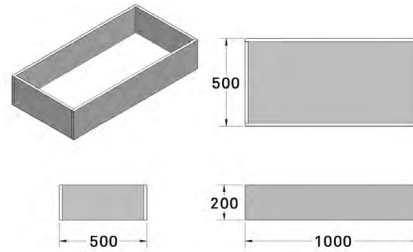

SMP-12
1200 W

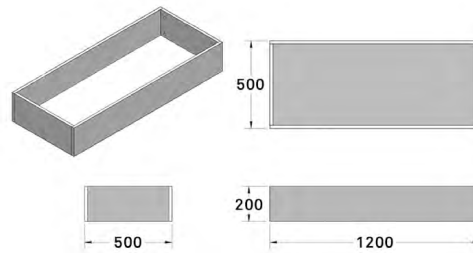

SMP-15
1500 W

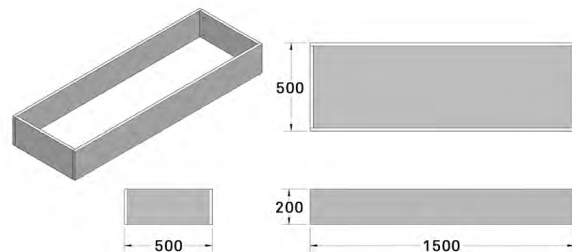

SMP-16
1600 W

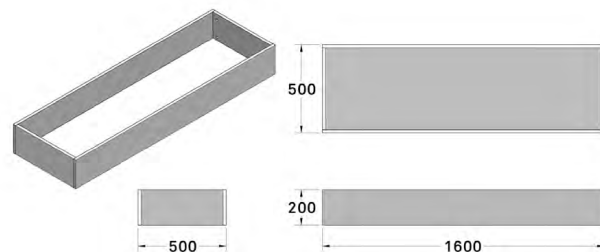

SMP-20
2000 W

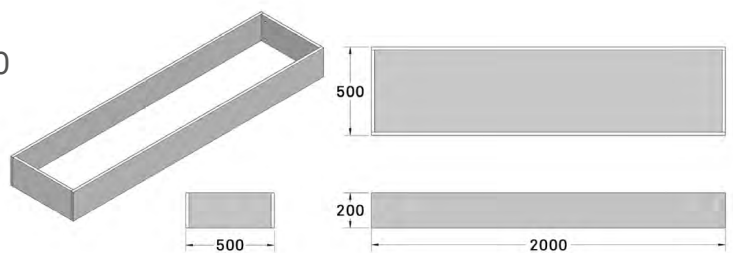

STANDARD FEATURES

25mm thick MFC top and bottom panel with 2mm ABS impact resistant edging.
 The rest of the carcass and doors are in 18mm thick MFC with 2mm ABS impact resistant edging.
 Chrome plated key lock as standard.
 Assembled with steel and zinc alloy fittings and wooden dowels.
 Complete with plastic adjustable feet.

MFC FINISHES



Melamine Faced Chipboard (MFC) is available in both 18mm and 25mm unless otherwise stated:
 Clay*, Graphite* and Silver* is 18mm only and Gloss White** is a premium finish with a 10% addition charge.

Colour Disclaimer: Printed images and digital images may appear differently to the final MFC finish.

LOCK OPTIONS

Key Lock **Standard**

Suffix - K

Our standard lock for all locker units purchased, unless stated otherwise. This simple locking system is ideal for both multiple users or single, long-term use.

Two keys are supplied per lock.
Key series can be mastered at extra cost



Digital Lock

Suffix - D - Private/Public Use

This keyless digital lock comes in choices of silver or black. Its two functions can be changed to suit its user.

The (default) private function is for users to set a pin code for repeated use, making it ideal for places of work. The public function allows users to set a four digit pin code which is used only once before being erased once opened, then it is available for the next user.

2 x AAA batteries are initially supplied but then to be personally replaced



RFID Plate Lock

Suffix - KL RFID

This stylish RFID front plate lock is designed to be opened with a card and can be programmed for either private or public use.

One card programmer device is required per order, weather that is for one lock or one thousand locks.

Featuring a power latch enabling intuitive 'push shut' closing system for fast locking doors.

Each lock comes with one card however additional cards can be purchased separately.
4 x AA batteries are initially supplied but then to be personally replaced



Lock shown with programmer

Value Mechanical Lock

Suffix - KL15 - Private Use

This cost-effective black mechanical lock is suited best for users that prefer not to use or keep a card or key.

This lock has a private function where the user sets a code for repeated use, with a reset switch to change the code while the door is open.

Public use lock available upon request; this lets the user set a four pin code only once before being erased once opened for the next user.

This is ideal for places that requires multiple use.

The coloured window shows when the lock is open or in use. If a code has been forgotten it can be recovered using a master key **sold separately**



Private use lock shown above.

Round Mechanical Lock

Suffix - KL10 - Private Use Only

This compact black mechanical lock is suited best for users that prefer not to use or keep a key. This lock has a private function only, meaning a set code will be used repeatedly, ideal for places of work.

If a code has been forgotten it can be recovered using a code retrieval key **sold separately**



Rectangular Mechanical Lock

Suffix - KL20 - Private Use Only

This flush black mechanical lock is suited best for users that prefer not to use or keep a key. This lock has a private function only, meaning a set code will be used repeatedly. Ideal for places of work. The coloured window shows when the lock is in use and the dials auto-scramble to 0-0-0-0 to hide the code for convenience after use.

If a code has been forgotten it can be recovered using a master key **sold separately**



RFID Button Lock

This simple RFID button can be opened with a card, band, tag or sticker for personalisation of keys. Easily visible if the door is unlocked then the button will protrude beyond the surface of the door. Cards and bands are purchased separately.

4 x AA batteries are initially supplied but then to be personally replaced



RFID LED Button Lock

This simple RFID button can be opened with a card, band, tag or sticker for personalisation of keys. Easily visible if the door is unlocked then the button will protrude beyond the casing and an LED will show green when available and red for locked.

Cards and bands are purchased separately.
3 x AA Lithium batteries are initially supplied but then to be personally replaced

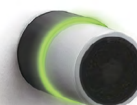

ENVIRONMENTAL

Material Content

Components are constructed of the following



MFC



Zinc Castings



Steel

Recycled Content

Contains up to 44.60% of Recycled Material



Recycled Content (% By Weight)

Recyclability

The range is 99% recyclable

99%

SENATOR 3 R'S

Senator is committed to continually improving the sustainability of all environmental aspects within our business. To meet both international standards and our own environmental targets we apply the three R's principle -**Reduce, Reuse and Recycle.**

Whilst recycling is the element which receives the most exposure it is actually the last option available and should never be the prime target in anyone's battle to reduce waste. It is our duty as individuals and as a company to initially attempt to **Reduce** usage. Then we should look to **Reuse** wherever possible and finally, only after these two processes have been exhausted, should we consider **Recycling.**

Reduce
Reuse
Recycle



DESIGN By Senator

Our team of talented in house designers are responsible for creating elegant, innovative furniture designs which not only look beautiful, but minimise the impact on the world around us. personal taste.

They come from all over the world, but are based in our Design Centre located in a quiet Lancashire village just outside the Ribble Valley. Our dedicated facility is over three floors which include studios, a materials test centre and prototyping lab.